

This drilling jig eliminates the time-consuming layout work usually associated with installing shelf supports or shelf-support sleeves, and guarantees that the holes will be exactly opposite each other and at equally spaced intervals. An entire panel up to 12" wide can be accurately chain drilled with no chance of error and no need for detailed measuring. (Long rods are available for material up to 24" wide, and extra-long rods for work up to 36" wide; see *Accessories*.)

Ten hole sizes can be drilled with the bushings that come as standard equipment, allowing you to use all of the shelf supports currently sold in North America. The 3/32" bushing is unhardened and can be drilled to any size for custom application.

### Assembling the Shelf-Drilling Jig

The jig comes unassembled to avoid damage in shipping. Assemble it as shown in **Figure 1**.

*Note: Place the clamp head and clamp nut on the threaded end of the rod.*

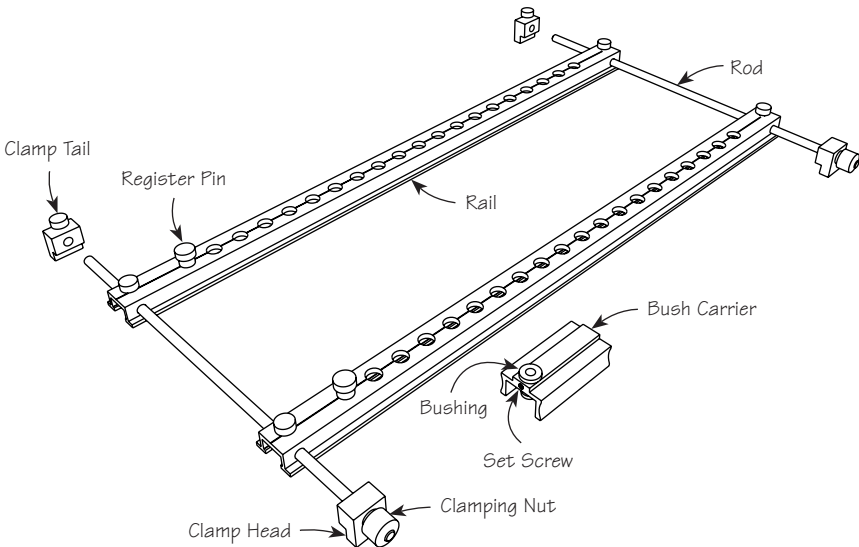

**Figure 1: Assembling the shelf-drilling jig.**

## Using the Shelf-Drilling Jig

1. Set the jig on the panel, and loosely position the clamp heads against one board edge.
2. Slide the clamp tails onto the rods until they are also against the board. Ensure that any excess rod extends only beyond the clamp tails. (See **Figure 2**.)
3. Snug up the clamps by pulling on the excess rod, then tightening the thumbscrew in the clamp tail. This step serves only to eliminate play. Final clamping is done with the clamping nut.
4. Set the rails at the desired inset from the board edges. Lock the rails to the rods using the thumbscrews.

**Tip:** Shelf supports/sleeves are usually set in about  $\frac{1}{6}$  of the total panel width. (See **Figure 4**.)

5. Position the rail ends at one end of the panel such that the first hole in each rail is at the desired distance for the first shelf support/sleeve. Make sure that the rail distances are exactly the same from the panel end. Tighten the clamping nuts to lock the position of the jig.

**Tip:** For ease of measuring, the first hole in a rail is centered  $2\frac{1}{2}$ " from the rail end.

6. Install the bushing of the desired size in the bush carrier and tighten the set screw with the hex key provided. Straddle the bush carrier on top of one rail, inserting the bushing in a hole on the rail where your first hole is to be drilled.

**Tip:** To verify that you have the correct bushing size, slide it over your drill bit. If you need a size that is not offered, the  $\frac{3}{32}$ " bushing is unhardened and can be drilled to any size while fixed in the bush carrier.

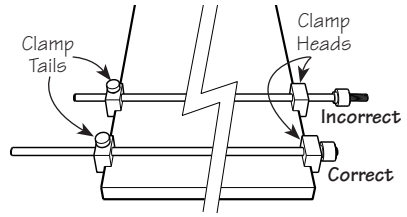

**Figure 2: Correct and incorrect clamp head set-up.**

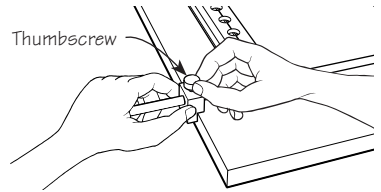

**Figure 3: Snugging the clamps.**

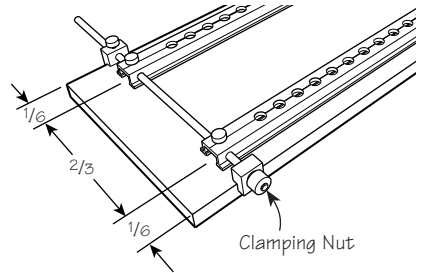

**Figure 4: Setting the rails.**

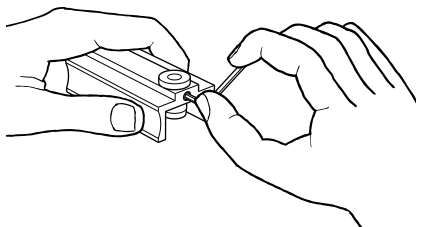

**Figure 5: Installing a bushing.**

7. With a stop collar on your drill bit to control the depth, drill the first hole, slide the bush carrier along the rail and continue drilling. When you reach the end of the rail, insert a register pin in the last hole drilled before transferring the bush carrier to the other rail. Drill the second row of holes in the same manner as the first, stopping when you reach the register pin in the first rail.
8. If your panel is longer than the rail set, loosen the clamping nuts, and slide the jig along the panel until you can put the register pins in the last drilled hole. This will ensure that the rows of holes continue in the same line as that of the previously drilled holes. Do not loosen the clamp tails or the thumbscrews at any time in this process, as these maintain your settings from the board edge.

### Face Dowelling

A single rail is a useful tool for face dowelling. Remove the rods and use the single rail with the bush carrier as a dowelling jig. Position the rail across a panel and secure with clamps, as shown in **Figure 8**.

To transfer the hole centers accurately to the mating vertical member, insert dowel centers into the drilled holes and use the rail as an alignment guide. Clamp the rail across the panel before lowering the vertical member onto the dowel centers.

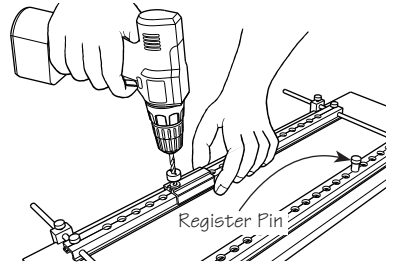

**Figure 6: Drilling the second row of holes.**

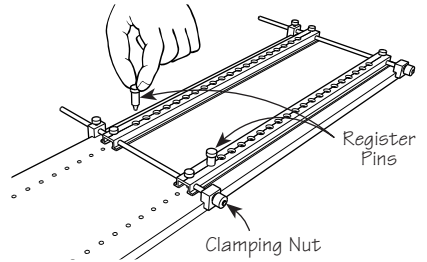

**Figure 7: Extending the line of holes.**

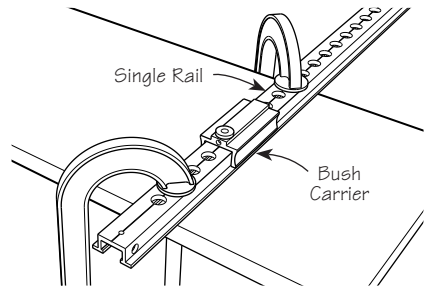

**Figure 8: Face dowelling.**

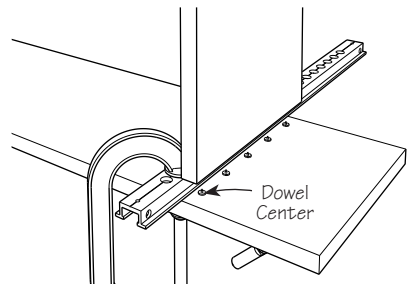

**Figure 9: Transferring hole centers.**

## Using Shelf-Support Sleeves

Many manufacturers of shelf supports also make available a mating sleeve that is inserted into the wood in lieu of just a drilled hole in the wood. The use of sleeves serves a dual purpose. Not only do they make a neater, more attractive installation of shelf supports, they prevent excessive wear of the predrilled hole, which is a common failing of supports installed in bare wood.

Always carefully measure the outside diameter (O.D.) of the sleeve to be installed. The predrill size is different for hardwood and particleboard than for softwood. Softwood will compress slightly and a snug fit will result when the predrilled hole is smaller than the O.D. of the sleeve (e.g., 7 mm I.D./8 mm O.D. sleeve is predrilled 7 mm in softwood and 7.5 mm in hardwood or particleboard). Hardwood and particleboard generally compress little and, therefore, a predrilled hole should be only slightly smaller than the sleeve O.D. If the predrill size is too small, damage will result to the sleeve in installation. If it is too large, the sleeve may fall out. It is best to experiment with different drill sizes in different woods. A sleeve-setting punch facilitates installation of the sleeve in a snug fit and eliminates damage to the sleeve and surrounding wood.

## Sleeve-Setting Punch

Included with this jig is a punch to install sleeves with a 7 mm inside diameter (I.D.), the most common size available in North America because it is used with 1/4" shanked paddle supports.

## Accessories

- 05J03.08** 5 mm Bushing
- 05J03.09** 6 mm Bushing
- 05J03.11** 6.75 mm Bushing
- 05J03.12** 7 mm Bushing
- 05J03.13** 7.5 mm Bushing
- 05J03.18** 8 mm (5/16") Bushing
- 05J03.21** 9 mm Bushing
- 05J03.20** 10 mm Bushing
- 05J03.10** 7/32" Bushing
- 05J03.17** 1/4" Bushing
- 05J03.19** 3/8" Bushing
- 05J03.22** 3/32" Soft Bushing
  
- 05J03.15** Pair of Long Rods
- 05J03.30** Pair of Extra-Long Rods
- 00K61.02** 7 mm Sleeve-Setting Punch
- 05J06.06** Tapered Register Pin
- 05J06.12** Bush Carrier and Hex Key